

TOP30/260-2 TOP30/375-2 TOP30/400-2 SOLAR TURBO TOWER 30 HRC

TURBO TOWER 30 HRC SOLAR ZBS16/83/120/150S-2MA/MRA

ZBS22/83/120/150S-2MA/MRA ZBS30/83/150S-2MA ZBS16/30/170S-2solarMA

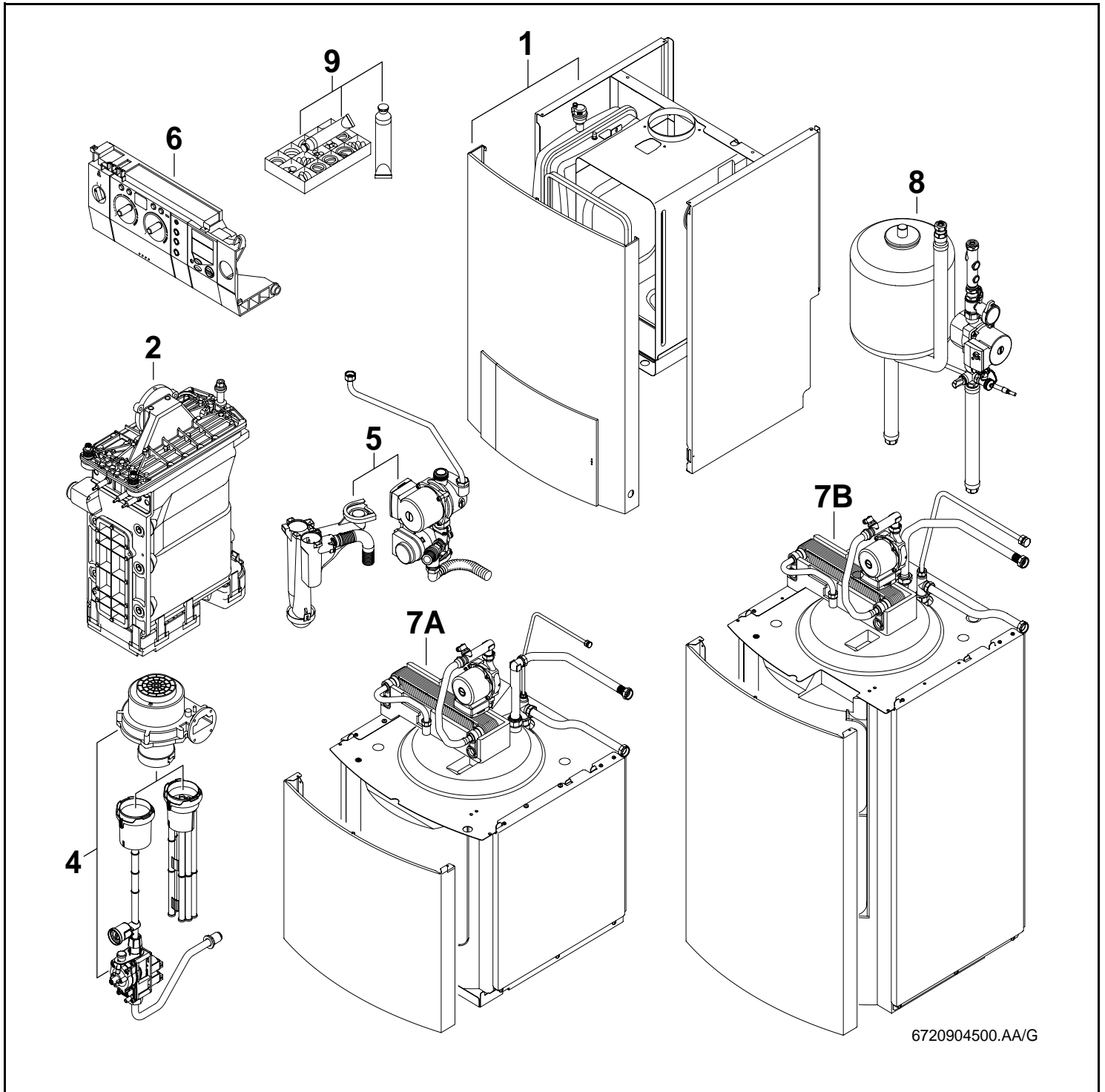

Wichtige Hinweise

- Ersatzteile dürfen nur von einem zugelassenen Installateur eingebaut werden!
- Die genannten Preisgruppen können sich während der Gültigkeit dieser Ersatzteilliste ändern. Wir empfehlen Ihnen daher, die Preisgruppen anhand der jeweils gültigen Preisliste zu prüfen.
- Im Anhang finden Sie:
 - die Übersetzungen aller verwendeten Teilebezeichnungen
 - eine Übersicht der Gerätetypen und Länder, für die diese Ersatzteilliste gilt.

Important notes

- The spare parts may only be installed by an approved installer!
- The price groups quoted may change during the period of validity of this spare parts list. We therefore advise you to check the price groups against the current price list.
- In the appendix you will find:
 - a list of translations of the names of all parts used
 - a list of the models and countries to which this spare parts list applies.

Indications importantes

- L'installation des pièces de rechange doit être effectuée par un professionnel qualifié !
- Les groupes de prix indiqués peuvent changer durant la durée de validité de la présente liste des pièces de rechange. Nous vous recommandons donc de vérifier les groupes de prix au moyen de la liste de prix correspondante en vigueur.
- Veuillez trouver en annexe :
 - les traductions de toutes les désignations des pièces utilisées
 - une vue globale des types de chaudières et des pays pour lesquels la présente liste des pièces de rechange est valable.

Avvertenze importanti

- Le parti di ricambio possono essere montate esclusivamente da personale qualificato ed in possesso dei requisiti tecnico-professionali (L. 46/90).
- Durante il periodo di validità della presente lista ricambi, i gruppi inerenti i prezzi riportati, possono essere soggetti a cambiamenti. Pertanto, è sempre consigliata una verifica basata sul confronto tra i gruppi prezzi riportati ed il relativo listino prezzi in vigore.
- In appendice sono reperibili:
 - traduzione di ogni descrizione relativa alle varie parti di ricambio
 - elenco di sigle e codici, corrispondente ai vari paesi di destinazione.

Indicaciones importantes

- ¡Los repuestos solamente deben ser montados por los servicios técnicos oficiales de la marca!
- Los grupos de precios citados pueden sufrir alteraciones durante el período de vigencia de esta lista de repuestos. Recomendamos por ello contrastar los grupos de precios en base a las respectivas listas de precios vigentes.
- En el anexo podrá encontrar:
 - la traducción de todas las denominaciones de piezas empleadas
 - una relación de los tipos de aparato y países en los que se aplica esta lista de repuestos.

Belangrijke aanwijzing

- Onderdelen mogen alleen door een erkend installateur worden vervangen!
- De genoemde prijsgroepen uit de onderdelenlijsten kunnen worden vergeleken met de nu geldende prijsgroepenlijst. Aanbevolen wordt de prijslijst te controleren op de nu geldende data.
- In de bijlage vindt u:
 - de vertalingen van de gebruikte onderdelentekeningen
 - een overzicht van toesteltypen en de landen waarvoor deze onderdelenlijst bedoeld is.

Ersatzteilliste
Spare parts list

Liste des pièces de rechange
Lista parti di ricambio

Lista de repuestos
Onderdelenlijst

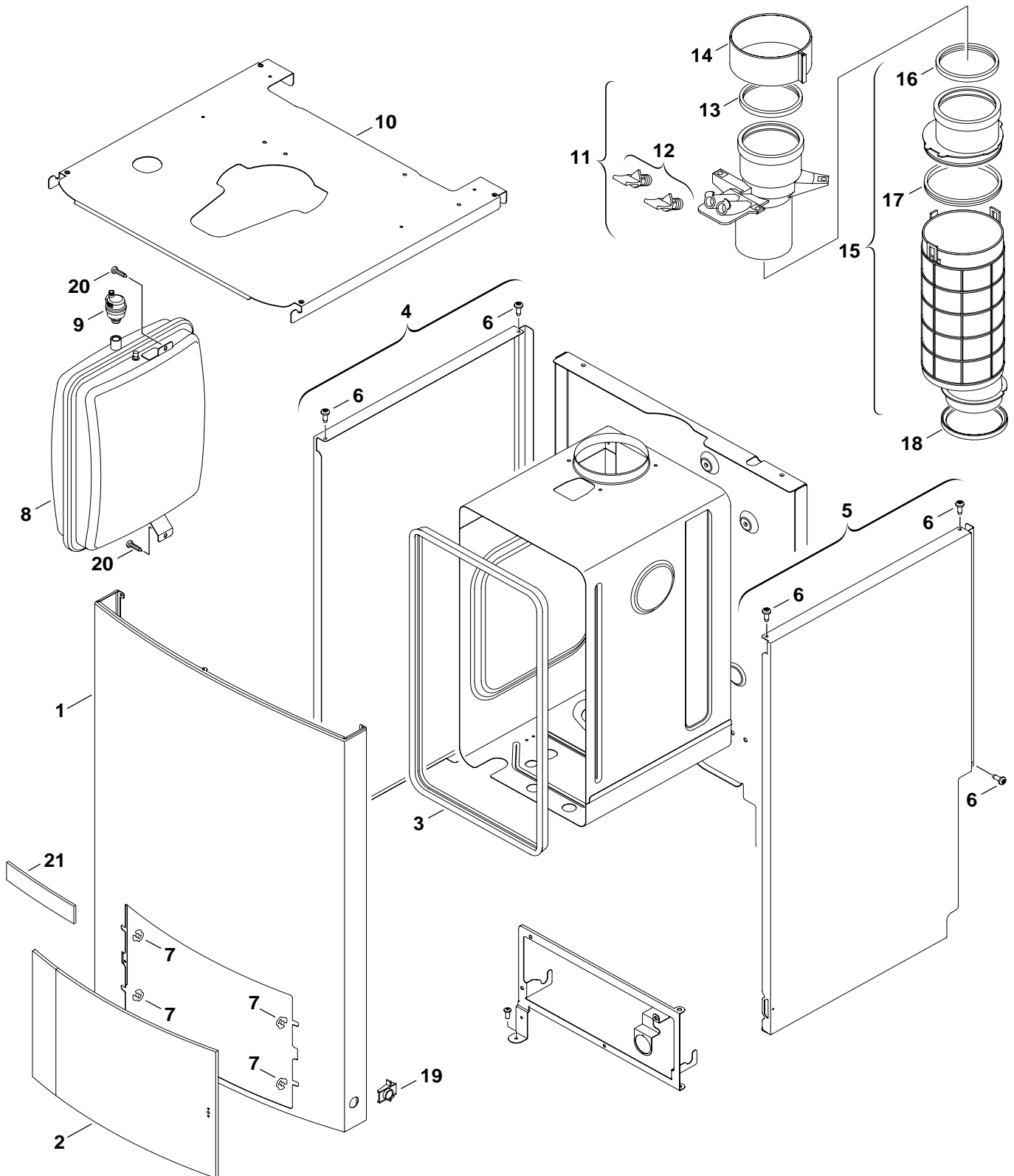

6720904501.AB/G

1

Blechteile
Sheet metal
Pièces de tôle
Parti di lamiera
Piezas de chapa
Mantel

TOP 30/260-2 TOP 30/375-2 TOP 30/400-2 SOLAR TURBO TOWER 30 HRC
TURBO TOWER 30 HRC SOLAR ZBS16/83/120/150S-2MA/MRA
ZBS22/83/120/150S-2MA/MRA ZBS30/83/150S-2MA
ZBS16/30/170S-2solarMA

Ersatzteilliste
Spare parts list

Liste des pièces de rechange
Lista parti di ricambio

Lista de repuestos
Onderdelenlijst

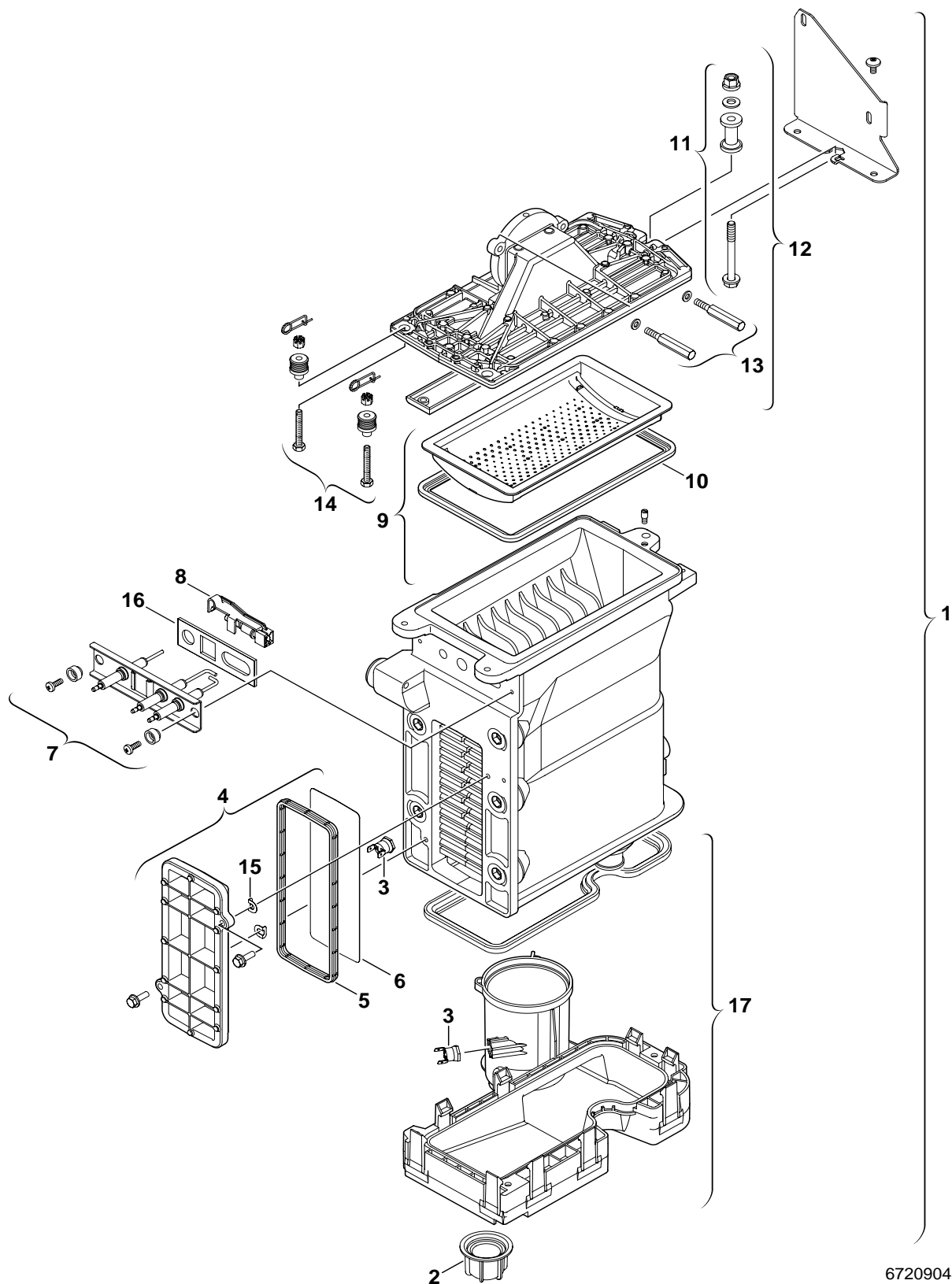

6720904513.AA/G

2

Brenner/Wärmeübertrager
Burner/Heat exchanger
Brûleur/Caloporteur
Bruciatore/Blocco lamellare
Quemador/Intercambiador de calor
Brander/Warmtewisselaar

TOP 30/260-2 TOP 30/375-2 TOP 30/400-2 SOLAR TURBO TOWER 30 HRC
TURBO TOWER 30 HRC SOLAR ZBS16/83/120/150S-2MA/MRA
ZBS22/83/120/150S-2MA/MRA ZBS30/83/150S-2MA
ZBS16/30/170S-2solarMA

Ersatzteilliste
Spare parts list

Liste des pièces de rechange
Lista parti di ricambio

Lista de repuestos
Onderdelenlijst

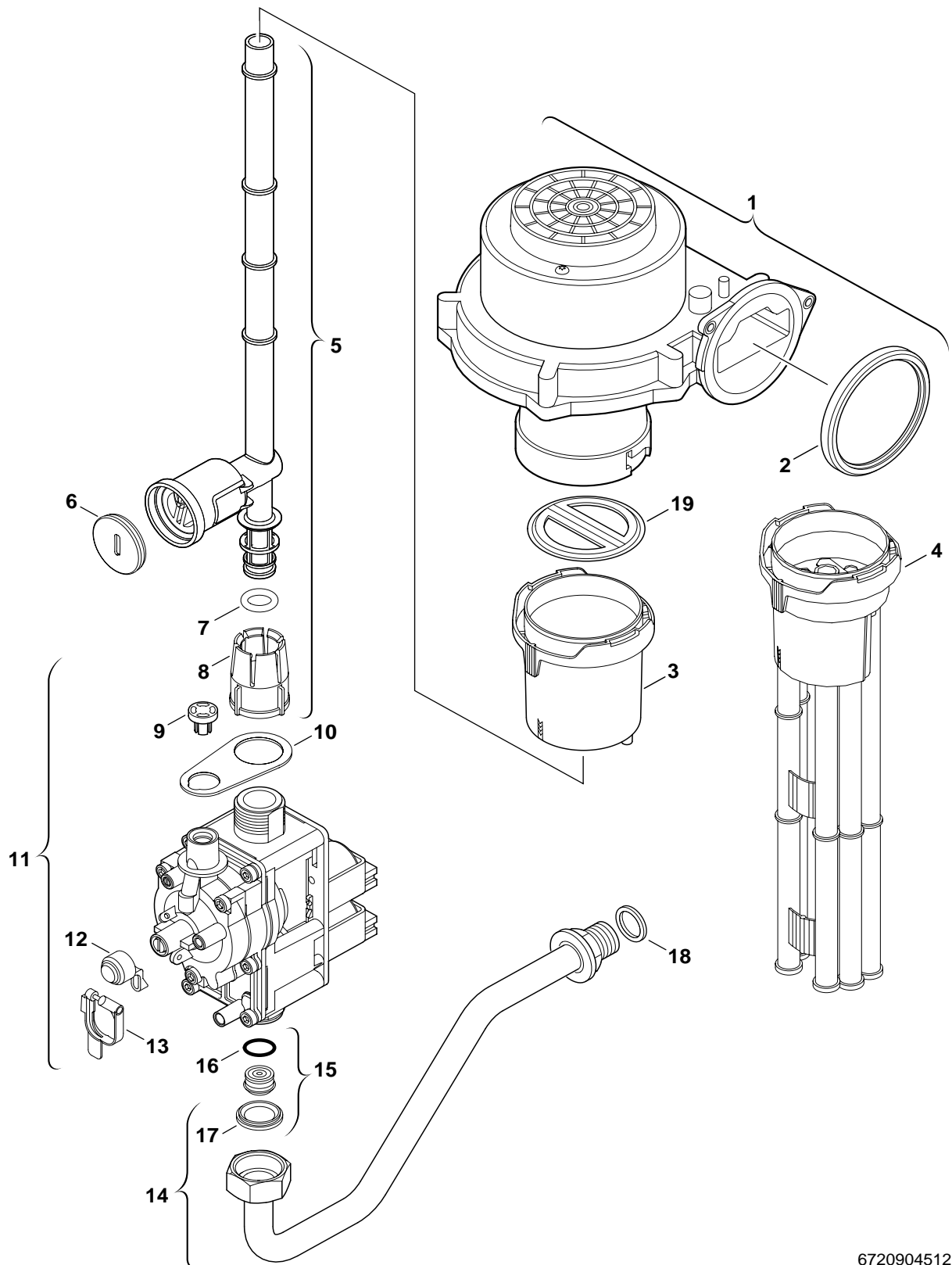

6720904512.AA/G

4

Gasarmatur
Gas valve
Bloc gaz
Gruppo gas
Cuerpo de gas
Gasregelblok

TOP 30/260-2 TOP 30/375-2 TOP 30/400-2 SOLAR TURBO TOWER 30 HRC
TURBO TOWER 30 HRC SOLAR ZBS16/83/120/150S-2MA/MRA
ZBS22/83/120/150S-2MA/MRA ZBS30/83/150S-2MA
ZBS16/30/170S-2solarMA

Pos	Bezeichnung description dénomination descrizioni descripcón benaming	S-Nr.	Bestell-Nr. ordering no. n° d'ordine n° d'ordine número el ordenar bestelnummer	PG	Gasart gas type type gaz tipo gas tipo gas gassoorte	TOP 30/260-2	TOP 30/375-2	TOP 30/400-2 SOLAR	TURBO TOWER 30 HRC	TURBO TOWER 30 HRC SOLAR	ZBS16/120S-2MA	ZBS16/150S-2MA	ZBS16/170S-2solarMA	ZBS16/83S-2MA	ZBS16/83S-2MRA	ZBS22/120S-2MA	ZBS22/120S-2MRA	ZBS22/150S-2MA	ZBS22/83S-2MA	ZBS30/150S-2MA	ZBS30/170S-2solarMA	ZBS30/83S-2MA	Bemerkungen remarks remarques osservazioni observaciones opmerking
1	Gebälse		8 717 204 343 0	51							■	■	■	■	■								
1	Gebälse		8 717 204 373 0	53		■	■	■	■	■						■	■	■	■	■	■	■	
2	Dichtring		8 729 000 183 0	13		■	■	■	■	■	■	■	■	■	■	■	■	■	■	■	■	■	
3	Luftbegrenzer		8 711 000 260 0	19							■	■	■	■	■								
3	Luftbegrenzer		8 711 000 282 0	30		■	■	■															
4	Luftbegrenzer		8 711 000 257 0	21					■	■					■	■	■	■	■	■	■	■	
5	Gasrohr		8 710 725 500 0	23		■	■	■	■	■					■	■	■	■	■	■	■	■	
5	Gasrohr		8 710 725 502 0	24							■	■	■	■	■								
6	Plombe (10x)		8 712 305 092 0	15		■	■	■	■	■	■	■	■	■	■	■	■	■	■	■	■	■	
7	O-Ring (10x)		8 710 205 089 0	11		■	■	■	■	■	■	■	■	■	■	■	■	■	■	■	■	■	
8	Überwurfmutter		8 713 301 117 0	09		■	■	■	■	■	■	■	■	■	■	■	■	■	■	■	■	■	
9	Kappe (10x)		8 715 503 344 0	12		■	■	■	■	■	■	■	■	■	■	■	■	■	■	■	■	■	
10	Dichtung		8 710 103 165 0	05		■	■	■	■	■	■	■	■	■	■	■	■	■	■	■	■	■	
11	Gasarmatur CE427		8 747 003 773 0	47											■	■	■				■		
11	Gasarmatur CE427	0404	8 747 003 773 0	47																	■	■	■
11	Gasarmatur CE427	0700	8 747 003 773 0	47					■	■													
11	Gasarmatur CE427	0800	8 747 003 773 0	47											■								
11	Gasarmatur CE427	1400	8 747 003 773 0	47													■	■					
11	Gasarmatur CE427	3600	8 747 003 773 0	47		■	■	■															
11	Gasarmatur CE427	0404	8 747 003 508 0	47								■											
11	Gasarmatur CE427	0404,5000	8 747 003 508 0	47									■										
11	Gasarmatur CE427	0800	8 747 003 508 0	47							■												
11	Gasarmatur CE427	1400	8 747 003 508 0	47							■												
11	Gasarmatur CE427	5000,5200	8 747 003 508 0	47											■						■		
11	Gasarmatur CE427	5200,5300	8 747 003 508 0	47									■										
11	Gasarmatur CE427	5300,6000	8 747 003 508 0	47																	■		
11	Gasarmatur CE427	5300,6100	8 747 003 508 0	47											■								
11	Gasarmatur CE427	6100,7100	8 747 003 508 0	47																	■		
11	Gasarmatur CE427	7200	8 747 003 508 0	47											■								
11	Gasarmatur CE427	7400	8 747 003 508 0	47																	■		
12	Kappe (10x)		8 710 506 117 0	15		■	■	■	■	■	■	■	■	■	■	■	■	■	■	■	■	■	
13	Plombe (10x)		8 712 305 023 0	15		■	■	■	■	■	■	■	■	■	■	■	■	■	■	■	■	■	
14	Gaszuführungsrohr		8 710 735 205 0	38		■	■	■	■	■	■	■	■	■	■	■	■	■	■	■	■	■	
15	Drosselbuchse (38)		8 710 303 073 0	24	31											■							
15	Drosselbuchse (27)		8 710 303 074 0	24	31										■								
16	O-Ring (10x)		8 710 205 062 0	11											■		■						
17	Dichtscheibe 3/4" (10x)		8 710 103 043 0	12		■	■	■	■	■	■	■	■	■	■	■	■	■	■	■	■	■	
18	Dichtscheibe 1/2" (10x)		8 710 103 045 0	11		■	■	■	■	■	■	■	■	■	■	■	■	■	■	■	■	■	
19	Membranteller		8 715 505 801 0	19					■	■	■	■	■	■	■						■	■	■
	Gasart-Umbausatz 21,23>31		7 710 149 033	27												■	■						
	Gasart-Umbausatz 31>21,23		7 710 239 072	23												■	■						
	Gasart-Umbausatz 21,23>31		7 710 149 035	26								■	■	■									
	Gasart-Umbausatz 31>21,23		7 710 239 073	20								■	■	■									
	Gasartumbausatz 21,23 ->31		8 719 001 041 0	31																	■		
	Gasartumbausatz 31-> 21,23		8 719 001 042 0	25																	■		
	Gasart-Umbausatz 21,23>31	1400	7 710 149 033	27													■	■					
	Gasart-Umbausatz 21,23>31	1400	7 710 149 035	26							■												
	Gasart-Umbausatz 31>21,23	1400	7 710 239 072	23														■	■				
	Gasart-Umbausatz 31>21,23	1400	7 710 239 073	20							■												
	Gasart-Umbausatz 21,23>31	0700	7 710 149 033	27					■	■													
	Gasart-Umbausatz 31>21,23	0700	7 710 239 072	23					■	■													
	Gasartumbausatz 21,23 ->31	0404	8 719 001 041 0	31																		■	
TOP 30/260-2 TOP 30/375-2 TOP 30/400-2 SOLAR TURBO TOWER 30 HRC											Gasarmatur											4	
TURBO TOWER 30 HRC SOLAR ZBS16/83/120/150S-2MA/MRA											Gas valve												
ZBS22/83/120/150S-2MA/MRA ZBS30/83/150S-2MA											Bloc gaz												
ZBS16/30/170S-2solarMA											Gruppo gas												
											Cuerpo de gas												
											Gasregelblok												

Ersatzteilliste
Spare parts list

Liste des pièces de rechange
Lista parti di ricambio

Lista de repuestos
Onderdelenlijst

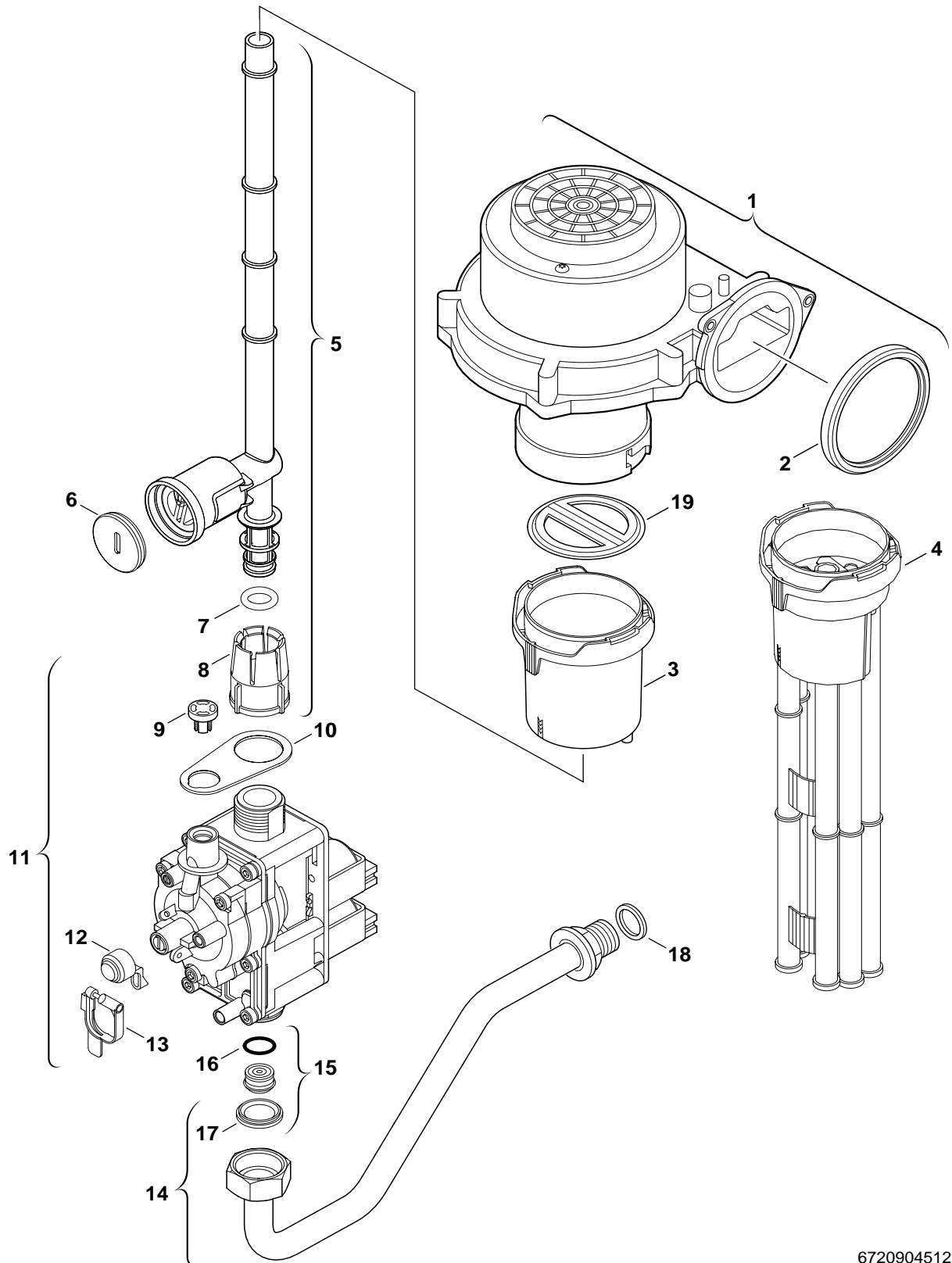

6720904512.AA/G

4

Gasarmatur
Gas valve
Bloc gaz
Gruppo gas
Cuerpo de gas
Gasregelblok

TOP 30/260-2 TOP 30/375-2 TOP 30/400-2 SOLAR TURBO TOWER 30 HRC
TURBO TOWER 30 HRC SOLAR ZBS16/83/120/150S-2MA/MRA
ZBS22/83/120/150S-2MA/MRA ZBS30/83/150S-2MA
ZBS16/30/170S-2solarMA

Ersatzteilliste
Spare parts list

Liste des pièces de rechange
Lista parti di ricambio

Lista de repuestos
Onderdelenlijst

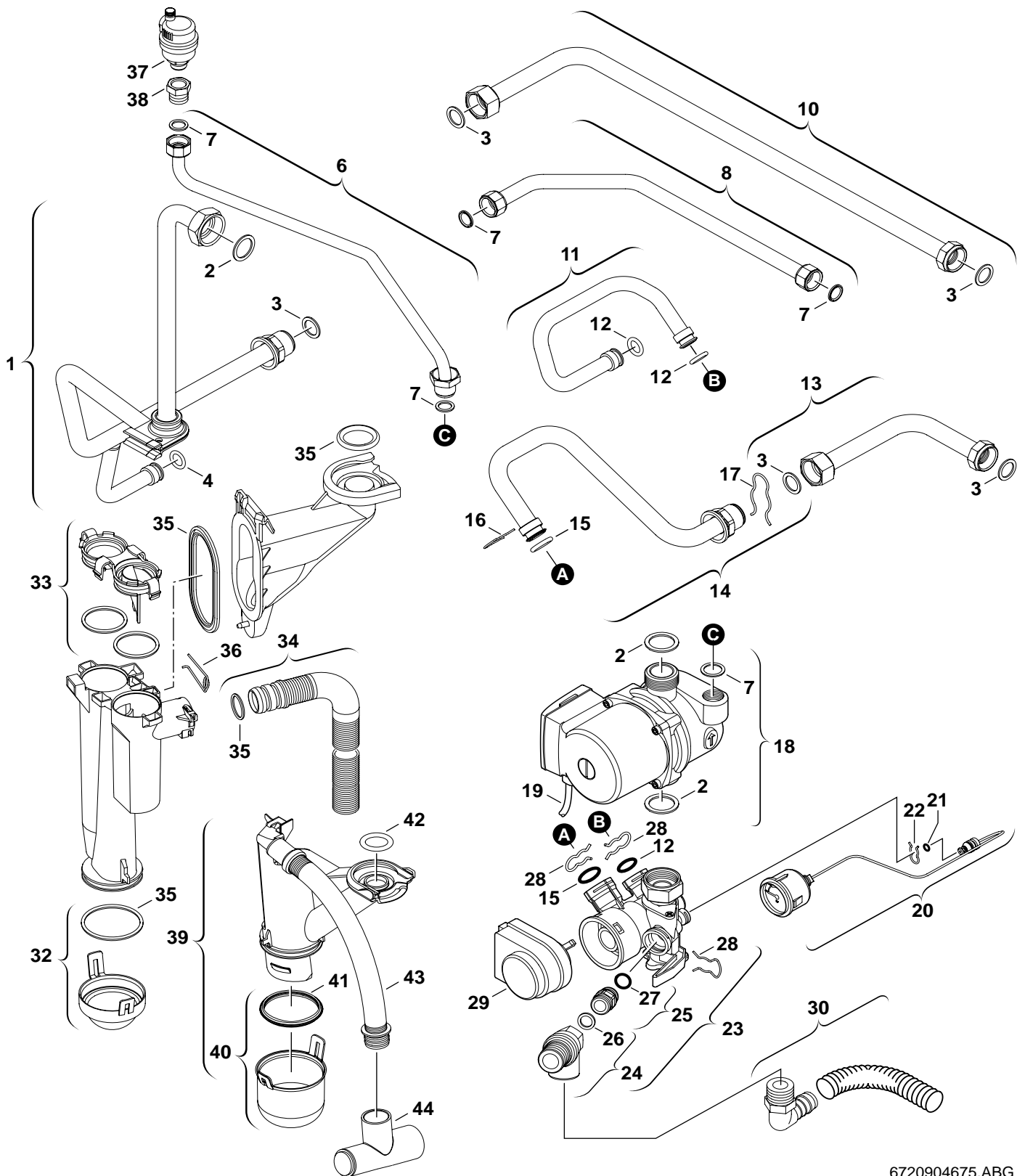

6720904675.ABG

5

Pumpe/Rohre
Pump/Tubes
Pompe/Tubes
Pompa/Raccordi
Bomba/Tubos
Pomp/Pijps

TOP 30/260-2 TOP 30/375-2 TOP 30/400-2 SOLAR TURBO TOWER 30 HRC
TURBO TOWER 30 HRC SOLAR ZBS16/83/120/150S-2MA/MRA
ZBS22/83/120/150S-2MA/MRA ZBS30/83/150S-2MA
ZBS16/30/170S-2solarMA

Ersatzteilliste
Spare parts list

Liste des pièces de rechange
Lista parti di ricambio

Lista de repuestos
Onderdelenlijst

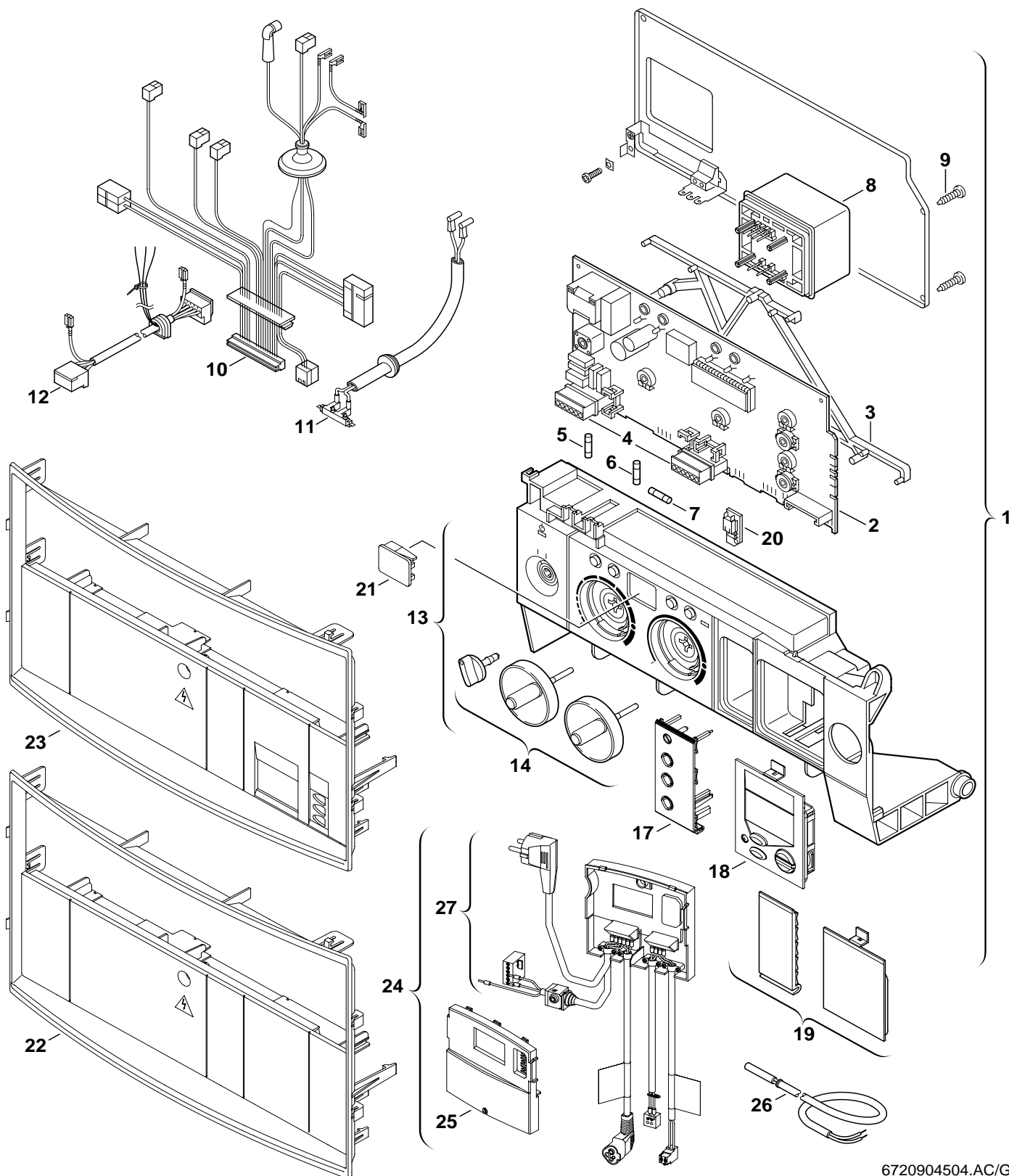

6720904504.AC/G

6

Schaltkasten
Control box
Tableau de commande
Quadro comandi
Caja de conexiones
Schakelkast

TOP 30/260-2 TOP 30/375-2 TOP 30/400-2 SOLAR TURBO TOWER 30 HRC
TURBO TOWER 30 HRC SOLAR ZBS16/83/120/150S-2MA/MRA
ZBS22/83/120/150S-2MA/MRA ZBS30/83/150S-2MA
ZBS16/30/170S-2solarMA

Ersatzteilliste
Spare parts list

Liste des pièces de rechange
Lista parti di ricambio

Lista de repuestos
Onderdelenlijst

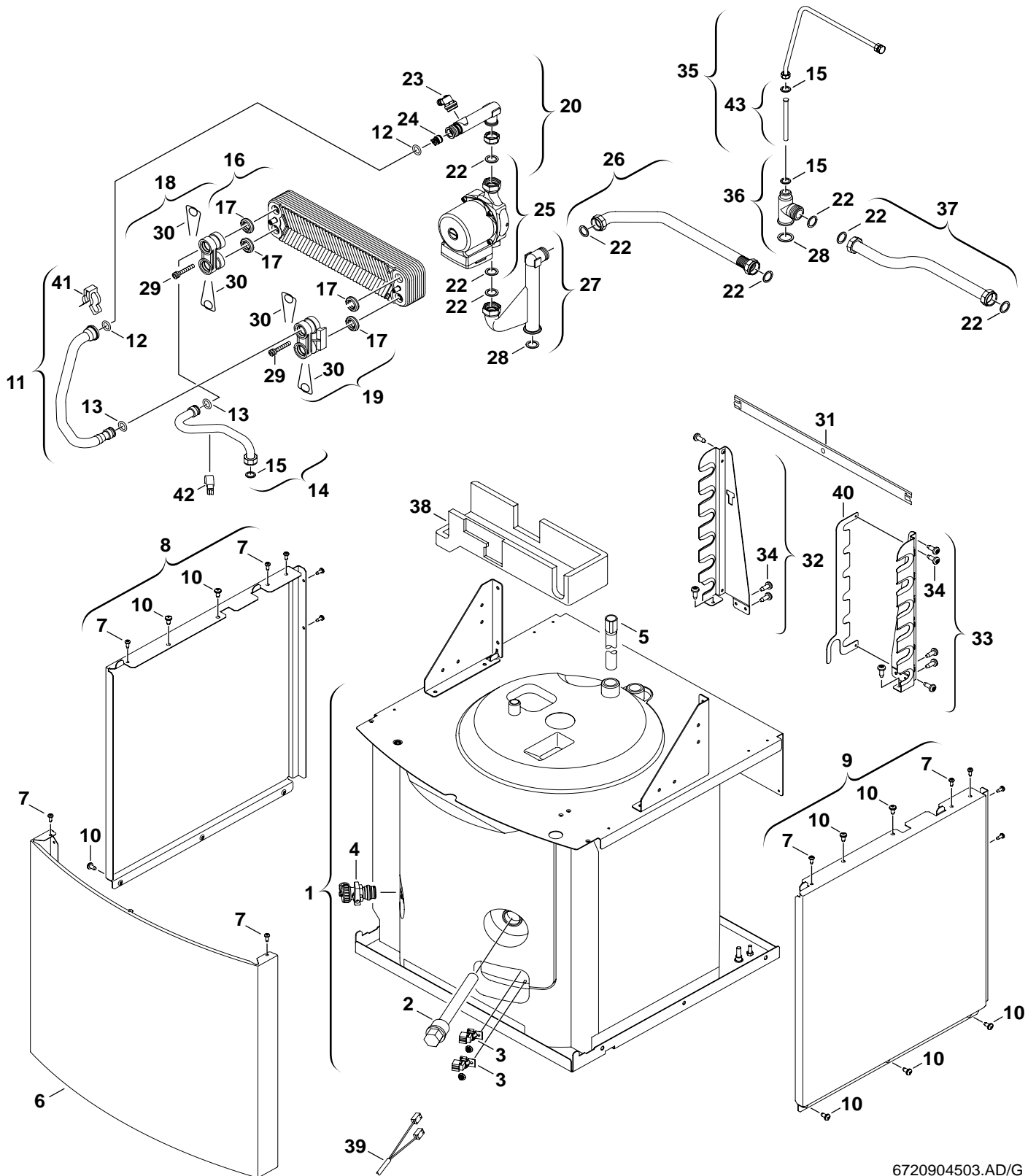

6720904503.AD/G

7 Speicherbehälter
Storage tank
Ballon
Bollitore
A Déposito
Voorraadvat

TOP 30/260-2 TOP 30/375-2 TURBO TOWER 30 HRC
30 HRC SOLAR ZBS16/83/120/150S-2MA/MRA
ZBS22/83/120/150S-2MA/MRA ZBS30/83/150S-2MA

TURBO TOWER

Ersatzteilliste
Spare parts list

Liste des pièces de rechange
Lista parti di ricambio

Lista de repuestos
Onderdelenlijst

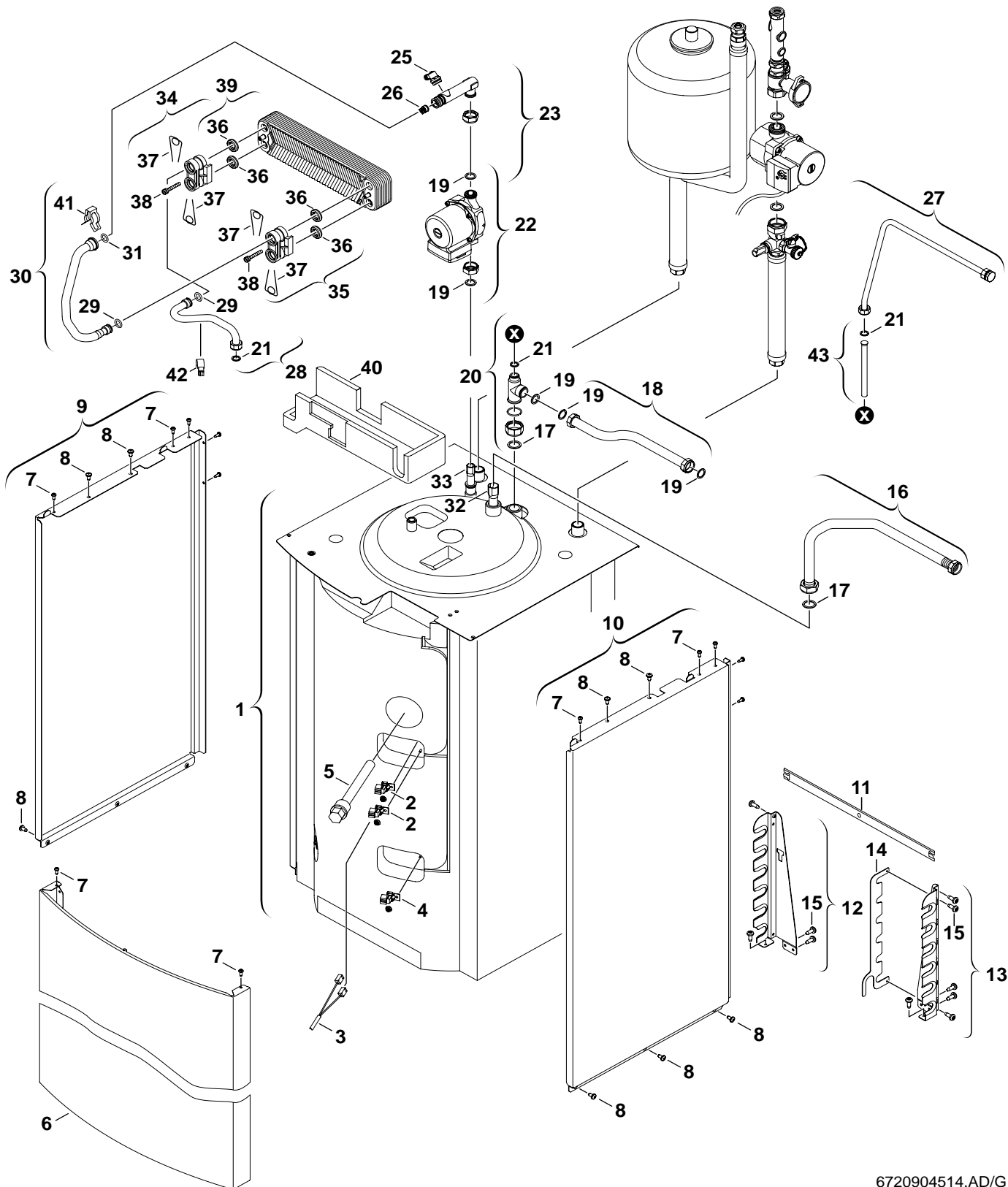

6720904514.AD/G

7 Speicherbehälter
Storage tank
Ballon
B Bollitore
Déposito
Voorraadvat

TOP 30/400-2 SOLAR TURBO TOWER 30 HRC SOLAR
ZBS16/170S-2solarMA ZBS30/170S-2solarMA

Ersatzteilliste
Spare parts list

Liste des pièces de rechange
Lista parti di ricambio

Lista de repuestos
Onderdelenlijst

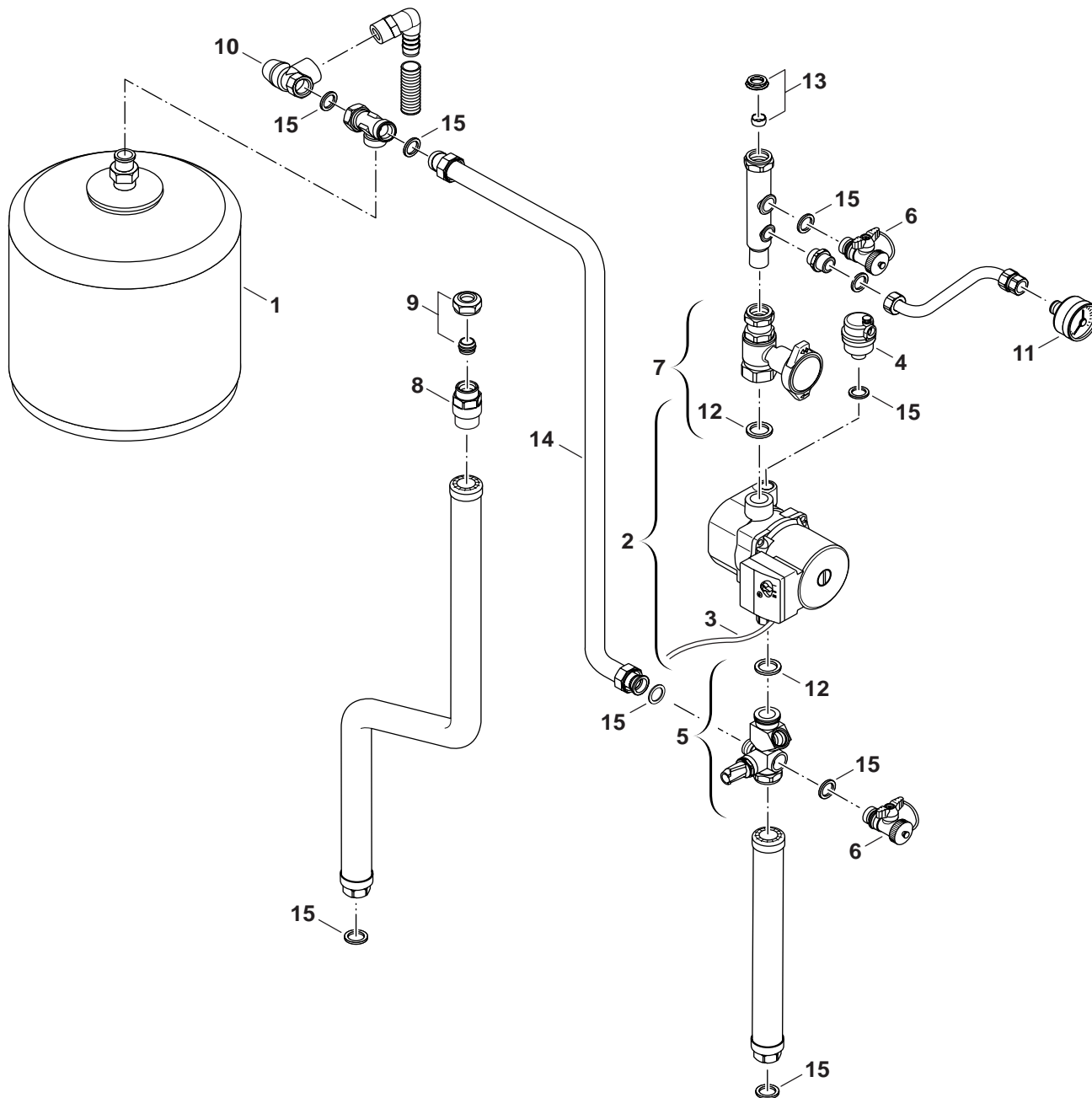

6720904872.AA/G

8

Solarhydraulik
Solar hydraulics
Hydraulique de solaire
Idraulica solare
Hidráulica solar
Hydrauliek solar

TOP 30/400-2 SOLAR TURBO TOWER 30 HRC SOLAR
ZBS16/170S-2solarMA ZBS30/170S-2solarMA

Ersatzteilliste
Spare parts list

Liste des pièces de rechange
Lista parti di ricambio

Lista de repuestos
Onderdelenlijst

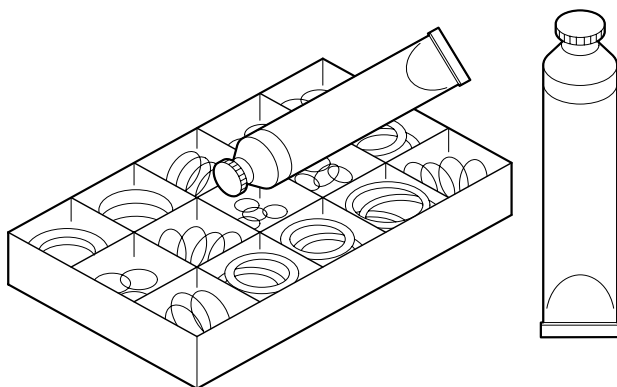

6720904217.AA/G

9

Wartung/Installation
Service/Installation
Service/Installation
Servicio/Instalazione
Servicio/Instalación
Service/Installatie

TOP 30/260-2 TOP 30/375-2 TOP 30/400-2 SOLAR TURBO TOWER 30 HRC
TURBO TOWER 30 HRC SOLAR ZBS16/83/120/150S-2MA/MRA
ZBS22/83/120/150S-2MA/MRA ZBS30/83/150S-2MA
ZBS16/30/170S-2solarMA

Übersetzungsliste
List of translations

Liste des traductions
Traduzione delle descrizioni

Lista de traducciones
Vertalinglijst

Pos	Description	Denomination	Descrizione	Descripción	Benaming
1	Element of construction	Groupe de construction	Gruppo di costruzione	Grupo de construccion	Montagegroep
1	Covering sheet	Couvercle	Coperchio	Chapa de protección	Afdichting
2	Door	Porte	Pannelo frontale	Puerta	Deur
3	Seal-Plate-Combustion Chamber	Joint	Guarnizione	Junta	Pakkingring
4	Sideshield left	Façade gauche	Penelli laterali sinistra	Chapa cuadro a la izquierda	Zijpaneel links
5	Sideshield right	Façade droit	Penelli laterali a destra	Chapa cuadro a la derecha	Zijpaneel rechts
6	Screw tapping no10 x 13 pan head	Vis BZ 4,8x13 (10x)	Vite BZ 4,8x13 (10x)	Tornillo BZ 4,8x13 (10x)	Schroef BZ 4,8x13 (10x)
7	Wireform spring Set	Epingle	Molla	Clip de fijacion	Borgveer
8	Expansion vessel 18l	Vase d'expansion 18l	Vaso di espansione 18l	Vaso de expansión 18l	Expansievat 18l
9	Automatic purger	Purgeur	Valvola sfiato aria	Purgador	Vlotterontluchter
10	Covering sheet	Couvercle	Coperchio	Chapa de protección	Afdichting
11	Connector	Raccordement ventouse	Terminale condotto	Acoplamiento salida gas	Rookgasafvoerstuts
12	Grommet	Bouchon	Coperchietto	Tapon	Doorvoertule
13	Washer 80MM	Joint Ø80	Guarnizione Ø80	Junta Ø80	Pakkingring Ø80
14	Clip	Collier d.130	Staffa	Abrazadera	Klembeugel
15	Flue gas duct	Tuyau d'évacuation gaz	Condotta fumi	Tubo salida de gases	Afvoerpijp
16	Washer 80MM	Joint Ø80	Guarnizione Ø80	Junta Ø80	Pakkingring Ø80
17	Seal	Joint	Guarnizione	Anillo junta	Pakkingring
18	Flue pipe seal	Joint	Guarnizione	Anillo junta	Pakkingring
19	Lock set	Sachet de serrure	Coperchio	Conjunto cerradura	Afsluitingsset
20	Screw M6x13 phillips steel cross	Vis (10x)	Vite (10x)	Tornillo (10x)	Schroef (10x)
21	Trademark Junkers	Trademark Junkers	Trademark Junkers	Trademark Junkers	Trademark Junkers
2	Element of construction	Groupe de construction	Gruppo di costruzione	Grupo de construccion	Montagegroep
1	Heating block	Echangeur thermique	Blocco lamellare	Bloque de calor	Ketelblok
2	Nut	ECROU TR32 X 3	Sostegno	Soporte	Stuts
3	Temperature limit sensor	Limiteur de température	Limitatore temperatura	Limitador de temperatura	Temperatuurbegrenzer
4	Cover	Couvercle	Coperchio	Tapa	Deksel
5	Sealing	Joint	Guarnizione	Junta	Afdichting
6	Shield	Tôle de protection	Lamierino	Chapa protectora	Afschermplaat
7	Set of electrodes	Jeu d'électrodes	Set di elettrodi	Conjunto electrodo	Elektrodenset
8	Temperature sensor	Sonde de temperature	Sensore termometrico	Sensor de temperatura	Temperatuurvoeler
9	Burner	Brûleur	Brucciatore	Quemador	Brander
10	Burner sealing	Joint de brûleur	Guarnizione bruciatore	Junta de quemador	Brander afdichting
11	Fixing bolt	Joint de fixation	Set di fissaggio	Juego piezas de fijacion	Bevestigingsset
12	Cover	Couvercle	Coperchio	Tapa	Deksel
13	Fixing set	Joint de fixation	Set di fissaggio	Juego piezas de fijacion	Bevestigingsset
14	Fixing set	Joint de fixation	Set di fissaggio	Juego piezas de fijacion	Bevestigingsset
15	Clip	Rondelle (10x)	Rondella (10x)	Arandela (10x)	Onderlegging (10x)
16	Washer	Joint (10x)	Guarnizione (10x)	Junta (10x)	Afdichting (10x)
17	Flue gas collector	Coupe tirage antirefouleur	Cappa fumi	Seguro evacuación de gases	Valwindafleider
4	Element of construction	Groupe de construction	Gruppo di costruzione	Grupo de construccion	Montagegroep
1	Centrifugal blower	Ventilateur	Ventilatore	Ventilador	Ventilador
2	Washer	Joint	Guarnizione	Anillo junta	Pakkingring
3	Mixer	Chambre de melange	Modulo di miscelazio	Máquina de mezcla	Meng inrichting
4	Air limiter	Chambre de melange	Modulo di miscelazio	Máquina de mezcla	Meng inrichting
5	Pipe - gas	Tube gaz	Tubo gas	Tubo de gas	Gaspijp
6	Lead seal	Plomb (10x)	Piombino (10x)	Plomo precinto (10x)	Loodje (10x)
7	O-ring	O-ring (10x)	Anello tenuta (10x)	Anillo tórico (10x)	O-ring (10x)
8	Unit Union	Ecrou	Dado	Tuerca	Wartelmoer
9	Protective cap	Capot de protection (10x)	Sigillo (10x)	Capuchón protector (10x)	Beschermkap (10x)
10	Washer	Joint	Guarnizione	Junta	Pakkingring
11	Gas valve ce427	Bloc gaz CE427	Gruppo gas CE427	Cuerpo de gas CE427	Gasregelblok CE427
12	Protective cap	Capot de protection (10x)	Sigillo (10x)	Capuchón protector (10x)	Beschermkap (10x)
13	Lead seal	Plomb	Piombino (10x)	Plomo precinto (10x)	Loodje (10x)
14	Gas supply pipe	Tube arrivée gaz	Tubo gas	Tubo de entrada de gas	Gastoevoerpijp
15	Throttle bush (38)	Coussinet limiteur (38)	Buccola di strozzagio (38)	Válvula di laminazione (38)	Regelventiel geel (38)
16	O-ring	Joint torique (10x)	Anello tenuta (10x)	Anillo tórico (10x)	O-ring (10x)

Übersetzungsliste
List of translations

Liste des traductions
Traduzione delle descrizioni

Lista de traducciones
Vertalinglijst

Pos	Description	Denomination	Descrizione	Descripción	Benaming
17	Fibre washer 23.9 X 17.2 X 1.5 (10x)	Joint 3/4" (10x)	Guarnizione 3/4" (10x)	Junta 3/4" (10x)	Afdichting 3/4" (10x)
18	Washer 18.6 X 13.5 X 1.5 (10x)	Joint 1/2" (10x)	Guarnizione 1/2" (10x)	Junta 1/2" (10x)	Afdichting 1/2" (10x)
19	bearing plate	Membrane	Piatello	Platillo de membrana	Overdrachtplaat met stift
	Gas conversion set 21,23>31	Kit de transformation de gaz 21,23>31	Kit conversione gas 21,23>31	Kit de conversión de gas 21,23>31	Gasombouwsset 21,23>31
	Gas conversion set 31>21,23	Kit de transformation de gaz 31>21,23	Kit conversione gas 31>21,23	Kit de conversión de gas 31>21,23	Gasombouwsset 31>21,23
	Gas conversion kit 21,23>31	Kit de transf.de gaz 21,23>31	Kit conversione gas 21,23>31	Kit de conversión de gas 21,23>31	Gasombouwsset 21,23>31
	Gas conversion kit 31>21,23	Kit de transf.de gaz 31>21,23	Kit conversione gas 31>21,23	Kit de conversión de gas 31>21,23	Gasombouwsset 31>21,23
	Gas conversion set	Kit de transformation de gaz	Kit conversione gas	Kit de conversión de gas	Gasombouwsset
5	Element of construction	Groupe de construction	Gruppo di costruzione	Grupo de construccion	Montagegroep
1	Pipe	Tube	Tubo	Tubo	Pijp
2	Washer 1" (10x)	Joint 1" (10x)	Guarnizione 1" (10x)	Junta 1" (10x)	Afdichting 1" (10x)
3	Fibre washer 23.9 X 17.2 X 1.5 (10x)	Joint 3/4" (10x)	Guarnizione 3/4" (10x)	Junta 3/4" (10x)	Afdichting 3/4" (10x)
4	O-ring 13,87x3,53	O-ring 13,87x3,53 (10x)	Anello tenuta 13,87x3,53 (10x)	Anillo tórico 13,87x3,53 (10x)	O-ring 13,87x3,53 (10x)
6	Pipe - venting	Tube de dégazage	Separatore	Conducto de purga	Ontluchtingspijp
7	Washer 18.6 X 13.5 X 1.5 (10x)	Joint 1/2" (10x)	Guarnizione 1/2" (10x)	Junta 1/2" (10x)	Afdichting 1/2" (10x)
8	Pipe	Tube	Tubo	Tubo	Pijp
10	Flow pipe	Tuyauterie	Tubo di raccordo	Tubo agua	Aansluitpijp
11	Pipe	Tube	Tubo	Tubo	Pijp
12	O-ring 13,87x3,53	O-ring 13,87x3,53 (10x)	Anello tenuta 13,87x3,53 (10x)	Anillo tórico 13,87x3,53 (10x)	O-ring 13,87x3,53 (10x)
13	Flow pipe	Tuyauterie	Tubo di raccordo	Tubo agua	Aansluitpijp
14	Return pipe	Tube de raccordement retour chauffage	Tubazione di ritorno	Tubo di ritorno	Retourleiding
15	O-ring	O-ring (10x)	Anello tenuta (10x)	Anillo tórico (10x)	O-ring (10x)
16	Wireform spring	Epingle (10x)	Molla (10x)	Clip de fijacion (10x)	Borgveer (10x)
17	Wireform spring (10x)	Epingle (10x)	Molla (10x)	Clip de fijacion (10x)	Borgveer (10x)
18	Pump	Circulateur	Pompa	Bomba	Pomp
19	Cable	Faisceau circulateur	Cabliaggio de pompa	Cable de bomba	Pompkabel
20	Manometer	Manomètre	Manometro	Manómetro	Manometer
21	O-ring	O-ring (10x)	Anello tenuta (10x)	Anillo tórico (10x)	O-ring (10x)
22	Wireform spring	Epingle (10x)	Molla (10x)	Clip de fijacion (10x)	Borgveer (10x)
23	3-way valve	Vanne 3 voies	3-vie valvola	3-vías válvula	3-wegklep
24	Safety relief valve 3bar	Soupape de sécurité 3bar	Valvola sicurezza 3bar	Válvula de sobrepresión 3bar	Veiligheidsklep 3bar
25	Adapter	Raccord	Adattore	Adaptador	Adapter
26	Washer	Joint (10x)	Guarnizione (10x)	Junta (10x)	Afdichting (10x)
27	O-ring 13,87x3,53	O-ring 13,87x3,53 (10x)	Anello tenuta 13,87x3,53 (10x)	Anillo tórico 13,87x3,53 (10x)	O-ring 13,87x3,53 (10x)
28	Wireform spring	Epingle (10x)	Molla (10x)	Clip de fijacion (10x)	Borgveer (10x)
29	Motor	Servomoteur	Motore	Motor	Motor
30	Hose	Flexible	Tubo flessibile	Tubo flexible	Slang
32	Protective cap	Capot de protection	Sigillo	Capuchón protector	Beschermkap
33	Cover	Couvercle	Coperchio nero	Tapa	Deksel
34	Corrugated pipe	Tuyau flexible	Tubo ondulato	Tubo ondolano	Flexibele leiding
35	Set of O-rings	Joint torique	Set di anello tenuta	Conjunto de anillo tórico	O-ring
36	Clamping spring	Ressort (10x)	Molla (10x)	Clip de fijación (10x)	Klemveer (10x)
37	Automatic purger	Purgeur	Valvola sfiato aria	Purgador	Vlotterontluchter
38	Adapter 3/8"	Raccord 3/8"	Adattore 3/8"	Adaptador 3/8"	Adapter 3/8"
39	Siphon	Siphon	Sifone	Sifón	Sifon
40	Cover	Couvercle	Coperchio nero	Tapa	Deksel
41	Washer set	Sachet de joints (10x)	Set di guarnizioni (10x)	Conjunto de juntas (10x)	Set af dichting (10x)
42	O-Ring 26,34 x 5,33	O-Ring 26,34x 5,33	O-Ring 26,34 x 5,33	O-Ring 26,34 x 5,33	
43	Hose	Flexible	Tubo flessibile	Tubo flexible	Slang
44	Condensation drainage	Evacuation de la condensats	Condense uscita	Descarga de condensados	Condensafvoer
6	Element of construction	Groupe de construction	Gruppo di costruzione	Grupo de construccion	Montagegroep
1	Control unit	Tableau électrique	Cassetta ionizzazione	Aparato de mando	Besturingsautomaat
2	Printed circuit	Circuit imprimé	Scheda elettronica	Placa de circuito impreso	Print
3	Spacer	Entretoise (10x)	Distanziale (10x)	Collar distanziador (10x)	Afstandhouder (10x)
4	Set of plugs	Plots connexion	Morsetto	Conjunto de aneccion	Stekker set
5	Fusing element T2,5A (10x)	Fusible T2,5A (10x)	Fusibile T2,5A (10x)	Fusible T2,5A (10x)	Buissmeltveiligheid T2,5A (10x)
6	Fusing element T0,5A	Fusible T0,5A (10x)	Fusibile T0,5A (10x)	Fusible T0,5A (10x)	Buissmeltveiligheid T0,5A (10x)

Übersetzungsliste
List of translations

Liste des traductions
Traduzione delle descrizioni

Lista de traducciones
Vertalinglijst

Pos	Description	Denomination	Descrizione	Descripción	Benaming
7	Fusing element T1,6A	Fusible T1,6A (10x)	Fusibile T1,6A (10x)	Fusible T1,6A (10x)	Buismeltveiligheid T1,6A (10x)
8	Transformer	Transformateur	Trasformatore primario	Transformadores	Transformator
9	Screw (10x)	Vis (10x)	Vite (10x)	Tornillo (10x)	Schroef (10x)
10	Set of cables	Faisceau	Cablaggio	Conjunto cables	Kabel set
11	Ignition lead	Faisceau d'electrodes	Cavetto accensione	Conductor de alta tensión	Hoogspanningsleiding
12	Pump cable	Faisceau circulateur	Cabliaggio de pompa	Cable de bomba	Pompkabel
13	Casing light grey	Carter gris clair	Involucro grigio chiaro	Protector girar claro	Bescherm lichtgrijs
14	Rotary handles light grey	Croisillons gris clairs	Manopola grigio chiaro	Grifo de girar claro	Schakelknop lichtgrijs
17	TA211E/C1	TA211E/C1	TA211E/C1	TA211E/C1	TA211E/C1
18	GREENSTAR DIGITAL TIMER	GREENSTAR DIGITAL TIMER	DT 2(GRIGIO CHIARO)	DT2 "HELLGRAU"	
19	Shield light grey	Sachet caches gris clair	Mascherina grigio chiaro	Chapa cuadro girar claro	Paneel lichtgrijs
20	Code plug (12)	Cl de codage (12)	Spina codifica (12)	Conector codificador (12)	Codeer stekker (12)
21	Observation window	Hublot	Vetrinoo	Cristal de observación	Kijkglas
22	Shield	Cache	Mascherina	Chapa cuadro	Paneel
23	Shield	Cache	Mascherina	Chapa cuadro	Paneel
24	Controller	Régulateur	Regolator	Controlador	Regelaar
25	Covering sheet	Couvercle	Coperchio	Chapa de protección	Afdichting
26	Temperature sensor	Sonde de temperature	Sensore termometrico	Sensor de temperatura	Temperatuurvoeler
27	Cable	Faisceau	Cablaggio	Cable	Kabel
	Fusing element set T0,5/T1,6/T2,5/T3,15A	Sachet fusibles T0,5/T1,6/T2,5/T3,15A	Set di fusibili T0,5/T1,6/T2,5/T3,15A	Conjunto de fusible T0,5/T1,6/T2,5/T3,15A	Zekeringset T0,5/T1,6/T2,5/T3,15A
7A	Element of construction	Groupe de construction	Gruppo di costruzione	Grupo de construccion	Montagegroep
1	Reservoir 83 L	Ballon de stockage 83 L	Sostegno 83 L	Déposito 83 L	Reservoir 83 L
2	Anode	Anode	Anodo	Anodo	Anode
3	Temperature sensor	Sonde de temperature	Sensore termometrico	Sensor de temperatura	Temperatuurvoeler
4	KFE-HAHN ZUB.NR845	Robinet de vidange/remplissage ECS	KFE-Hahn Zub.Nr845	KFE-Hahn Zub.Nr845	KFE-Hahn Zub.Nr845
5	Inlet/Outlet tube	Tube d'arrivée/évacuation	Tube della presa/ entrata	Pipa del producto/de salida	Inlet/Outlet tube
6	Covering sheet	Couvercle	Coperchio	Chapa de protección	Afdichting
7	Screw tapping no10 x 13 pan head	Vis BZ 4,8x13 (10x)	Vite BZ 4,8x13 (10x)	Tornillo BZ 4,8x13 (10x)	Schroef BZ 4,8x13 (10x)
8	Side panel left	Côté gauche	Pannelo laterale sinistra	Pared lateral a la izquierda	Zijpaneel links
9	Side panel right	Côté droit	Pannelo laterale a destra	Pared lateral a la derecha	Zijpaneel rechts
10	Screw M6x13 phillips steel cross	Vis (10x)	Vite (10x)	Tornillo (10x)	Schroef (10x)
11	Pipe	Tube	Tubo	Tubo	Pijp
12	O-ring 17x4	O-ring 17 x4 (10x)	Anello tenuta 17x4 (10x)	Anillo tórico 17x4 (10x)	O-ring 17x4 (10x)
13	O-ring 13,87x3,53	O-ring 13,87x3,53 (10x)	Anello tenuta 13,87x3,53 (10x)	Anillo tórico 13,87x3,53 (10x)	O-ring 13,87x3,53 (10x)
14	Pipe	Tube	Tubo	Tubo	Pijp
15	Washer 18.6 X 13.5 X 1.5 (10x)	Joint 1/2" (10x)	Guarnizione 1/2" (10x)	Junta 1/2" (10x)	Afdichting 1/2" (10x)
16	Heat exchanger	Corps de chauffe	Blocco lamellare	Bloque de calor	Ketelblok
17	Seal plate heat exchanger	Joint d'étanchéité	Gomma di tenuta	Junta de goma	Afdichtingsrubber
18	Connection bush	Douille filetée	Piattello di collegamento	Casquillo roscado	Aansluitstuk (bus)
19	Connection bush	Douille filetée	Piattello di collegamento	Casquillo roscado	Aansluitstuk (bus)
20	Connection union	Raccord sonde sanitaire	Raccordo	Conexión	Koppeling
22	Fibre washer 23.9 X 17.2 X 1.5 (10x)	Joint 3/4" (10x)	Guarnizione 3/4" (10x)	Junta 3/4" (10x)	Afdichting 3/4" (10x)
23	Vent valve	Dégazeur	Valvola di scarico	Válvula de purga de aire	Ontluchtventiel
24	Swing check valve	Clapet anti-retour	Ritorno di blocco	Valvula de retención	Terugslagventiel
25	Pump	Circulateur	Pompa	Bomba	Pomp
26	Flow pipe	Tube	Tubo di raccordo	Tubo agua	Aansluitpijp
27	Flow pipe	Tuyauterie	Tubo di raccordo	Tubo agua	Aansluitpijp
28	Washer 1" (10x)	Joint 1" (10x)	Guarnizione 1" (10x)	Junta 1" (10x)	Afdichting 1" (10x)
29	Screw & washer assembly m5	Vis avec joint	Set di fissaggio	Juego piezas de fijacion	Bevestigingsset
30	Clamping spring	Ressort (10x)	Molla (10x)	Clip de fijación (10x)	Klemveer (10x)
31	Fixing bracket	Support	Angolare	Angulo soporte	Steunbeugel
32	Fixing bracket	Tôle de fixation	Angolare	Angulo soporte	Steunhoek
33	Fixing bracket	Tôle de fixation	Angolare	Angulo soporte	Steunhoek
34	Screw tapping no10 x 13 pan head	Vis BZ 4,8x13 (10x)	Vite BZ 4,8x13 (10x)	Tornillo BZ 4,8x13 (10x)	Schroef BZ 4,8x13 (10x)
35	Flow pipe	Tuyauterie	Tubo di raccordo	Tubo agua	Aansluitpijp
36	Flow pipe	Tuyauterie	Tubo di raccordo	Tubo agua	Pijp
37	Flow pipe	Tuyauterie	Tubo di raccordo	Tubo agua	Aansluitpijp

Übersetzungsliste
List of translations

Liste des traductions
Traduzione delle descrizioni

Lista de traducciones
Vertalinglijst

Pos	Description	Denomination	Descrizione	Descripción	Benaming
38	Insulation	Isolation	Isolamento	Aislamiento	Isolatie
39	Cable	Faisceau	Cablaggio	Cable	Kabel
40	Connection plate	Plaque de jonction	Lamierino	Placa de unión	Vangschaal
41	Clip (10x)	Clip (10x)	Graffa (10x)	Grapa (10x)	Klem (10x)
42	Temperature sensor	Sonde de température	Sensore termometrico	Sensor de temperatura	Temperatuurvoeler
43	Flow pipe	Tuyauterie	Tubo di raccordo	Tubo agua	Aansluitpijp
7B	Element of construction	Groupe de construction	Gruppo di costruzione	Grupo de construccion	Montagegroep
1	Reservoir 170 l	Ballon de stockage 170 l	Sostegno 170 l	Déposito 170 l	Reservoir 170 l
2	Temperature sensor	Sonde de temperature	Sensore termometrico	Sensor de temperatura	Temperatuurvoeler
3	Cable	Faisceau	Cablaggio	Cable	Kabel
4	Temperature sensor	Sonde de temperature	Sensore termometrico	Sensor de temperatura	Temperatuurvoeler
5	Anode	Anode	Anodo	Anodo	Anode
6	Covering sheet	Couvercle	Coperchio	Chapa de protección	Afdichting
7	Screw tapping no10 x 13 pan head	Vis BZ 4,8x13 (10x)	Vite BZ 4,8x13 (10x)	Tornillo BZ 4,8x13 (10x)	Schroef BZ 4,8x13 (10x)
8	Screw M6x13 phillips steel cross	Vis (10x)	Vite (10x)	Tornillo (10x)	Schroef (10x)
9	Side panel left	Côté gauche	Pannelo laterale sinistra	Pared lateral a la izquierda	Zijpaneel links
10	Side panel right	Côté droit	Pannelo laterale a destra	Pared lateral a la derecha	Zijpaneel rechts
11	Fixing bracket	Support	Angolare	Angulo soporte	Steunbeugel
12	Fixing bracket	Tôle de fixation	Angolare	Angulo soporte	Steunhoek
13	Fixing bracket	Tôle de fixation	Angolare	Angulo soporte	Steunhoek
14	Connection plate	Plaque de jonction	Lamierino	Placa de unión	Vangschaal
15	Screw tapping no10 x 13 pan head	Vis BZ 4,8x13 (10x)	Vite BZ 4,8x13 (10x)	Tornillo BZ 4,8x13 (10x)	Schroef BZ 4,8x13 (10x)
16	Flow pipe	Tuyauterie	Tubo di raccordo	Tubo agua	Aansluitpijp
17	Washer 1" (10x)	Joint 1" (10x)	Guarnizione 1" (10x)	Junta 1" (10x)	Afdichting 1" (10x)
18	Flow pipe	Tuyauterie	Tubo di raccordo	Tubo agua	Aansluitpijp
19	Fibre washer 23.9 X 17.2 X 1.5 (10x)	Joint 3/4" (10x)	Guarnizione 3/4" (10x)	Junta 3/4" (10x)	Afdichting 3/4" (10x)
20	Flow pipe	Tuyauterie	Tubo di raccordo	Tubo agua	Pijp
21	Washer 18.6 X 13.5 X 1.5 (10x)	Joint 1/2" (10x)	Guarnizione 1/2" (10x)	Junta 1/2" (10x)	Afdichting 1/2" (10x)
22	Pump	Circulateur	Pompa	Bomba	Pomp
23	Connection union	Raccord sonde sanitaire	Raccordo	Conexión	Koppeling
25	Vent valve	Dégazeur	Valvola di scarico	Válvula de purga de aire	Ontluchtventiel
26	Swing check valve	Clapet anti-retour	Ritorno di blocco	Valvula de retención	Terugslagventiel
27	Flow pipe	Tuyauterie	Tubo di raccordo	Tubo agua	Aansluitpijp
28	Pipe	Tube	Tubo	Tubo	Pijp
29	O-ring 13,87x3,53	O-ring 13,87x3,53 (10x)	Anello tenuta 13,87x3,53 (10x)	Anillo tórico 13,87x3,53 (10x)	O-ring 13,87x3,53 (10x)
30	Pipe	Tube	Tubo	Tubo	Pijp
31	O-ring 17x4	O-ring 17 x4 (10x)	Anello tenuta 17x4 (10x)	Anillo tórico 17x4 (10x)	O-ring 17x4 (10x)
32	Inlet/Outlet tube	Tube d'arrivée/évacuation	Tubo della presa/ entrata	Pipa del producto/de salida	Inlet/Outlet tube
33	Inlet/Outlet tube	Tube d'arrivée/évacuation	Tubo della presa/ entrata	Pipa del producto/de salida	Inlet/Outlet tube
34	Connection bush	Douille fileté	Piattello di collegamento	Casquillo roscado	Aansluitstuk (bus)
35	Connection bush	Douille fileté	Piattello di collegamento	Casquillo roscado	Aansluitstuk (bus)
36	Seal plate heat exchanger	Joint d'étanchéité	Gomma di tenuta	Junta de goma	Afdichtingsrubber
37	Clamping spring	Ressort (10x)	Molla (10x)	Clip de fijación (10x)	Klemveer (10x)
38	Screw & washer assembly m5	Vis avec joint	Set di fissaggio	Juego piezas de fijacion	Bevestigingsset
39	Heat exchanger	Corps de chauffe	Blocco lamellare	Bloque de calor	Ketelblok
40	Insulation	Isolation	Isolamento	Aislamiento	Isolatie
41	Clip (10x)	Clip (10x)	Graffa (10x)	Grapa (10x)	Klem (10x)
42	Temperature sensor	Sonde de température	Sensore termometrico	Sensor de temperatura	Temperatuurvoeler
43	Flow pipe	Tuyauterie	Tubo di raccordo	Tubo agua	Aansluitpijp
8	Element of construction	Groupe de construction	Gruppo di costruzione	Grupo de construccion	Montagegroep
1	Solar-Expansion vessel SAG 18	VASE D'EXPANSION SAG 18	SAG 18	Vaso de expansión SAG 18	Solar-Ausdehnungsgefäß SAG 18
2	Pump	Circulateur	Pompa	Bomba	Pomp
3	Pump cable	Faisceau circulateur	Cablaggio de pompa	Cable de bomba	Pompkabel
4	Automatic purger	Purgeur	Valvola sfiato aria	Purgador	Vlotterontluchter
5	Flow limiter	Limiteur de débit	Regolatore di flusso	Obturador	Debietbegrenzer
6	Service cock	Vanne d'arrêt chauffage	Llave de mantenimiento	Llave de manutención	Kraan onderhoud
7	Ball valve	Robinet à boule	Valvola a sfera	Válvula de bola	Kogelkraan

Gerätetypen Types of appliances	Types de chaudières Tipo apparecchi	Tipos de aplicaciones Toesteltypes	
Gerat Appliance Chaudiere Apparecchio Aparato Toestel	Bestell-Nr. ordering no. numero de commande n° d'ordine número el ordenar bestelnummer	Land Country Pay Paese Paese Land	Bemerkungen remarks remarques osservazioni observaciones opmerkingen
TOP 30/260-2 ZBS	7 714 311 026	Belgien	ZBS30/83S-2MA23S3600
TOP 30/375-2 ZBS	7 714 311 028	Belgien	ZBS30/150S-2MA23S3600
TOP 30/400-2 ZBS SOLAR	7 714 311 029	Belgien	ZBS30/170S-2solarMA23S3600
ZBS16/170S-2SOLARMA21	7 714 301 004	Deutschland	
ZBS16/83S-2MA21	7 714 301 001	Deutschland	
ZBS16/83S-2MRA21	7 714 301 000	Deutschland	
ZBS16/83S-2MRA23	7 714 311 000	Deutschland	
ZBS16/83S-2MRA31	7 714 321 000	Deutschland	
ZBS22/120S-2MA21	7 714 301 005	Deutschland	
ZBS22/120S-2MA23	7 714 311 005	Deutschland	
ZBS22/120S-2MRA21	7 714 301 002	Deutschland	
ZBS22/120S-2MRA23	7 714 311 002	Deutschland	
ZBS22/120S-2MRA31	7 714 321 002	Deutschland	
ZBS30/150S-2MA21	7 714 301 003	Deutschland	
ZBS30/150S-2MA23	7 714 311 003	Deutschland	
ZBS16/170S-2SOLARMA23	7 714 311 004	Deutschland,Österreich	
ZBS16/83S-2MA23	7 714 311 001	Deutschland,Österreich	
ZBS16/120S-2MA23S0800	7 714 311 030	Dänemark	
ZBS16/170S-2SOLARMA23S0800	7 714 410 031	Dänemark	
ZBS22/120S-2MA23S0800	7 714 311 031	Dänemark	
ZBS30/170S-2SOLARMA23S6100	7 714 410 033	Estland,Lettland,Litauen	
ZBS16/170S-2 SOLAR MA	7 714 410 027	Italien	
ZBS16/83S-2MA	7 714 410 028	Italien	
ZBS30/150S-2MA23S0404	7 714 410 017	Italien	
ZBS30/170S-2SOLARMA23S0404	7 714 410 018	Italien	
ZBS30/83S-2MA23S0404	7 714 410 016	Italien	
ZBS30/150S-2MA23 S7400	7 714 311 019	Kroatien	

Gerätetypen Types of appliances	Types de chaudières Tipo apparecchi	Tipos de aplicaciones Toesteltypes	
Gerat Appliance Chaudiere Apparecchio Aparato Toestel	Bestell-Nr. ordering no. numero de commande n° d'ordine número el ordenar bestelnummer	Land Country Pay Paese Paese Land	Bemerkungen remarks remarques osservazioni observaciones opmerkingen
ZBS22/120S-2MA23 S6100	7 714 311 012	Lettland	
ZBS30/150S-2MA23 S6100	7 714 311 013	Lettland	
TURBO TOWER 30 HRC	7 714 311 035	Niederlande	ZBS30/120S-2MA5S0700
TURBO TOWER 30 HRC SOLAR	7 714 311 036	Niederlande	ZBS30/170S-2solarMA5S0700
ZBS16/170S-2SOLARMA23S5300	7 714 410 032	Polen	
ZBS16/83S-2MA23S5300	7 714 311 014	Polen	
ZBS22/120S-2MA23S5300	7 714 311 015	Polen	
ZBS30/150S-2MA23S5300	7 714 311 016	Polen	
ZBS30/150S-2MA23 S6000	7 714 311 017	Serbien und Montenegro	
ZBS16/83S-2MA23S7200	7 714 311 051	Slovenien	
ZBS22/120S-2MA23 S7200	7 714 311 018	Slovenien	
ZBS16/83S-2MA23 S5200	7 714 311 009	Tschechien	
ZBS22/120S-2MA23 S5200	7 714 311 010	Tschechien	
ZBS30/150S-2MA23 S5200	7 714 311 011	Tschechien	
ZBS30/150S-2MA23 S7100	7 714 311 020	Ukraine	
ZBS16/83S-2MA23 S5000	7 714 311 006	Ungarn	
ZBS22/120S-2MA23 S5000	7 714 311 007	Ungarn	
ZBS30/150S-2MA23 S5000	7 714 311 008	Ungarn	
ZBS16/150S-2MA23S1400	7 714 410 021	Österreich	
ZBS22/150S-2MA23S1400	7 714 410 022	Österreich	
ZBS22/83S-2MA23S1400	7 714 410 020	Österreich	

BBT Thermotechnik GmbH
Sophienstr. 30-32
D-35576 Wetzlar

www.bbt-thermotechnik.com